

PTFF-180SM

PRECIOUS METAL BRUSHED DC MICRO MOTOR



32Lx20Wx15mmH (1.26Lx0.79Wx0.59inH)

VOLTAGE	1.0~12.0V
HOUSING LENGTH	32.1mm (1.26in)
WIDTH X HEIGHT	20.4 x 15.4mm (0.80 x 0.61in)
SHAFT LENGTH	42mm (1.65in)
SPEED (NO LOAD)	6500~7700 RPM
POWER (AT MAX EFF)	0.41~0.98W
TORQUE (AT MAX EFF)	7.5~15.0 g·cm (0.74~1.47 mN·m)
OPERATING TEMPERATURE	-40°C ~+80°C
WEIGHT	32g (1.13oz)

MODEL NUMBER	VOLTAGE (V)		NO LOAD		AT MAXIMUM EFFICIENCY					STARTING		
	OPERATING RANGE	NOMINAL	SPEED	CURRENT	SPEED	CURRENT	TORQUE		OUTPUT	TORQUE		CURRENT
			RPM	A	RPM	A	g·cm	mN·m	W	g·cm	mN·m	A
PTFF-180SM-2657	1.0~3.0	2.4	7700	0.13	6400	0.70	15.0	1.47	0.98	107	10.5	3.80
PTFF-180SM-10320	6.0~12.0	12.0	6500	0.028	5300	0.12	7.5	0.74	0.41	82	8.04	0.52

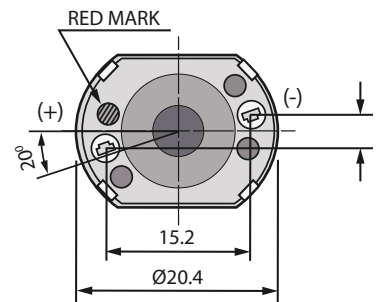
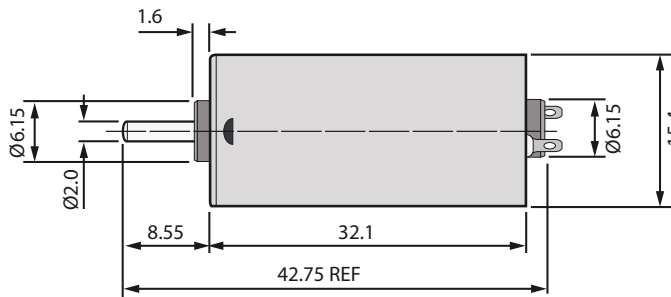
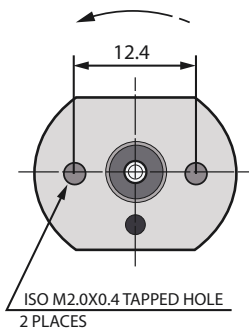

UNIT: mm

