

PTRE-280SA

PRECIOUS METAL BRUSHED DC MICRO MOTOR



24D x 31mmL (0.94D x 1.22inL)

VOLTAGE	4.5~7.5V
HOUSING LENGTH	30.5mm (1.20in)
DIAMETER	24mm (0.94in)
SHAFT LENGTH	45mm (1.77in)
SPEED (NO LOAD)	8200 RPM
POWER (AT MAX EFF)	2.29W
TORQUE (AT MAX EFF)	31.9 g·cm (3.13 mN·m)
OPERATING TEMPERATURE	-30°C ~+80°C
WEIGHT	43.6g (1.54oz)

MODEL NUMBER	VOLTAGE (V)		NO LOAD		AT MAXIMUM EFFICIENCY					STARTING		
	OPERATING RANGE	NOMINAL	SPEED	CURRENT	SPEED	CURRENT	TORQUE		OUTPUT	TORQUE		CURRENT
			RPM	A	RPM	A	g·cm	mN·m	W	g·cm	mN·m	A
PTRE-280SA-22120	4.5~7.5	6.0	8200	0.096	7000	0.56	31.9	3.13	2.29	216.8	21.25	3.23

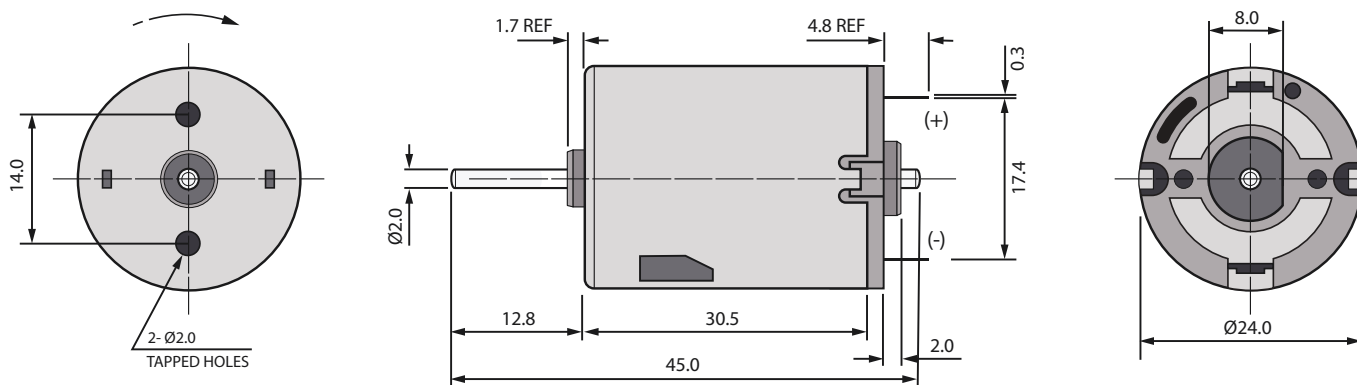

UNIT: mm

