

PTFS-050SH

CARBON BRUSHED DC MICRO MOTOR

27Lx16Wx12mmH (1.06Lx0.63Wx0.47inH)



VOLTAGE	2.0~6.0V
HOUSING LENGTH	26.7mm (1.05in)
WIDTH X HEIGHT	15.5mm x 11.8mm (0.61 x 0.46in)
SHAFT LENGTH	39mm (1.54in)
SPEED (NO LOAD)	4900 RPM
POWER (AT MAX EFF)	0.26W
TORQUE (AT MAX EFF)	6.6 g·cm (0.65 mN·m)
OPERATING TEMPERATURE	-20°C ~+60°C
WEIGHT	17g (0.6oz)

MODEL NUMBER	VOLTAGE (V)		NO LOAD		AT MAXIMUM EFFICIENCY					STARTING		
	OPERATING RANGE	NOMINAL	SPEED	CURRENT	SPEED	CURRENT	TORQUE	OUTPUT	TORQUE	CURRENT		
			RPM	A	RPM	A	g·cm	mN·m	W	g·cm	mN·m	A
PTFS-050SH-11180	2.0~6.0	4.0	4900	0.048	3645	0.14	6.6	0.65	0.26	25.79	2.53	0.40

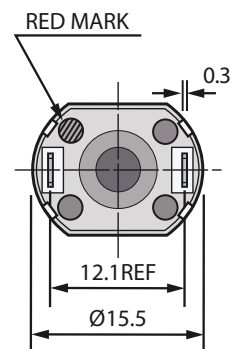
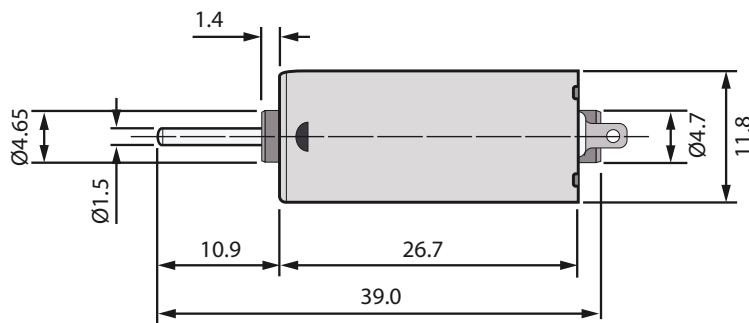
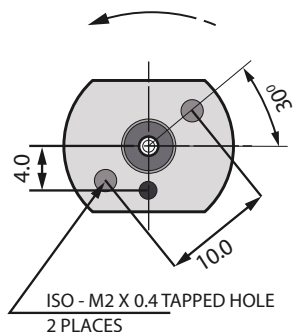

UNIT: mm

