

PTFS-130SA

CARBON BRUSHED DC MICRO MOTOR



25Lx20Wx15mmH (0.98Lx0.79Wx0.59inH)

VOLTAGE	9.0~15.0V
HOUSING LENGTH	25.1mm (0.99in)
WIDTH X HEIGHT	20.4 x 15.4mm (0.80 x 0.61in)
SHAFT LENGTH	38mm (1.5in)
SPEED (NO LOAD)	8254 RPM
POWER (AT MAX EFF)	1.03W
TORQUE (AT MAX EFF)	15.2 g·cm (1.49 mN·m)
OPERATING TEMPERATURE	-40°C ~+80°C
WEIGHT	24g (0.85oz)

MODEL NUMBER	VOLTAGE (V)		NO LOAD		AT MAXIMUM EFFICIENCY					STARTING		
	OPERATING RANGE	NOMINAL	SPEED RPM	CURRENT A	SPEED RPM	CURRENT A	TORQUE g·cm	TORQUE mN·m	OUTPUT W	TORQUE g·cm	TORQUE mN·m	CURRENT A
PTFS-130SA-09450	9.0~15.0	13.0	8254	0.047	6325	0.156	15.2	1.49	1.03	65.04	6.37	0.513

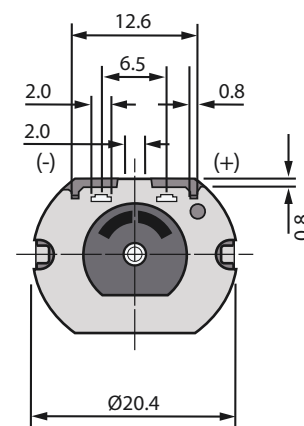
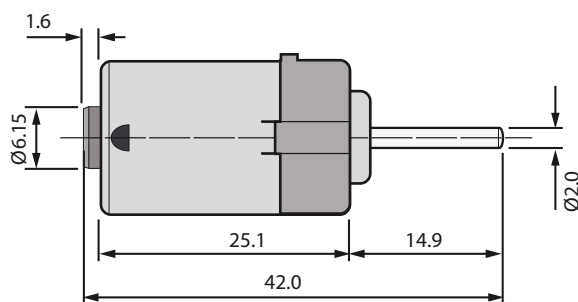
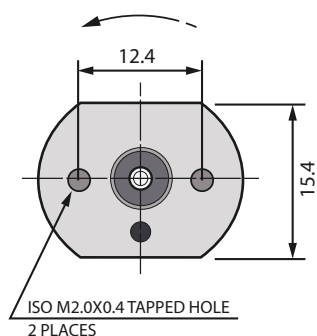

UNIT: mm

