

# PTFS-280SA

CARBON BRUSHED DC MICRO MOTOR

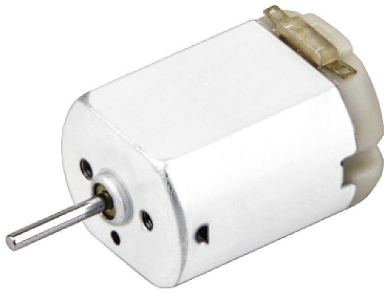

31Lx24Wx19mmH (1.22Lx0.94Wx0.75inH)

VOLTAGE	10.0~15.0V
HOUSING LENGTH	30.5mm (1.20in)
WIDTH X HEIGHT	24.2 x 18.55mm (0.95 x 0.73in)
SHAFT LENGTH	45mm (1.77in)
SPEED (NO LOAD)	12650 RPM
POWER (AT MAX EFF)	5.01W
TORQUE (AT MAX EFF)	45.5 g·cm (4.459 mN·m)
OPERATING TEMPERATURE	-30°C ~+70°C
WEIGHT	35g (1.23oz)

MODEL NUMBER	VOLTAGE (V)		NO LOAD		AT MAXIMUM EFFICIENCY					STARTING		
	OPERATING RANGE	NOMINAL	SPEED RPM	CURRENT A	SPEED RPM	CURRENT A	TORQUE g·cm	TORQUE mN·m	OUTPUT W	TORQUE g·cm	TORQUE mN·m	CURRENT A
PTFS-280SA-20150	10.0~15.0	13.5	12650	0.100	10737	0.55	45.5	4.459	5.01	300	29.4	3.08

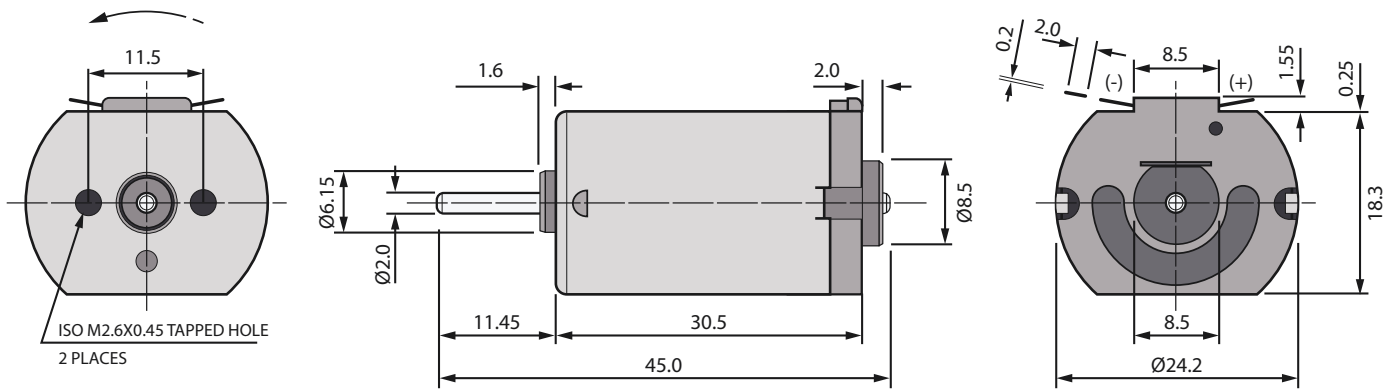

UNIT: mm

