

# PTRS-280SA

CARBON BRUSHED DC MICRO MOTOR



24D x 31mmL (0.94D x 1.22inL)

VOLTAGE	9.0~15.0V
HOUSING LENGTH	30.5mm (1.20in)
DIAMETER	24mm (0.94in)
SHAFT LENGTH	45mm (1.77in)
SPEED (NO LOAD)	8500 RPM
POWER (AT MAX EFF)	2.38W
TORQUE (AT MAX EFF)	35.6 g·cm (3.49 mN·m)
OPERATING TEMPERATURE	-30°C ~+70°C
WEIGHT	43.6g (1.54oz)

MODEL NUMBER	VOLTAGE (V)		NO LOAD		AT MAXIMUM EFFICIENCY					STARTING		
	OPERATING RANGE	NOMINAL	SPEED RPM	CURRENT A	SPEED RPM	CURRENT A	TORQUE g·cm	TORQUE mN·m	OUTPUT W	TORQUE g·cm	TORQUE mN·m	CURRENT A
PTRS-280SA-16200	9.0~15.0	12.0	8500	0.061	6970	0.33	35.6	3.49	2.38	198	19.4	1.56

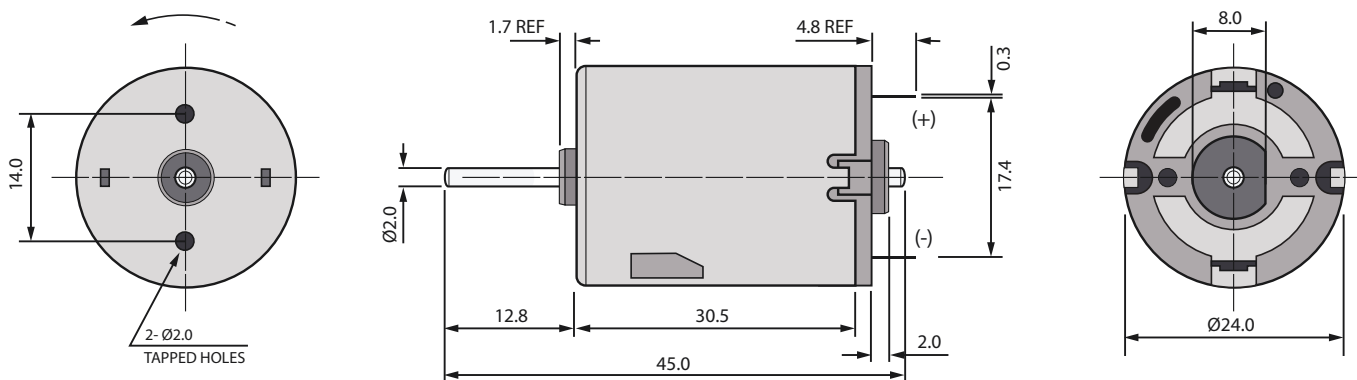

UNIT: mm

