

PTRS-540SA

CARBON BRUSHED DC MICRO MOTOR



38D x 50mmL (1.50D x 1.97inL)

| | |
|-----------------------|-------------------------|
| VOLTAGE | 8.0~16.0V |
| HOUSING LENGTH | 50.0mm (1.50in) |
| DIAMETER | 37.6mm (1.48in) |
| SHAFT LENGTH | 71.0mm (2.80in) |
| SPEED (NO LOAD) | 3461 RPM |
| POWER (AT MAX EFF) | 7.84W |
| TORQUE (AT MAX EFF) | 244.6 g·cm (23.97 mN·m) |
| OPERATING TEMPERATURE | -30°C ~+70°C |
| WEIGHT | 165g (5.82oz) |

| MODEL NUMBER | VOLTAGE (V) | | NO LOAD | | AT MAXIMUM EFFICIENCY | | | | STARTING | | | |
|------------------|-----------------|---------|--------------|--------------|-----------------------|--------------|----------------|----------------|-------------|----------------|----------------|--------------|
| | OPERATING RANGE | NOMINAL | SPEED RPM | CURRENT A | SPEED RPM | CURRENT A | TORQUE g·cm | TORQUE mN·m | OUTPUT W | TORQUE g·cm | TORQUE mN·m | CURRENT A |
| PTRS-540SA-32165 | 8.0~16.0 | 12.0 | 3461 | 0.13 | 2997 | 0.86 | 244.6 | 23.97 | 7.84 | 1825 | 178.9 | 5.6 |

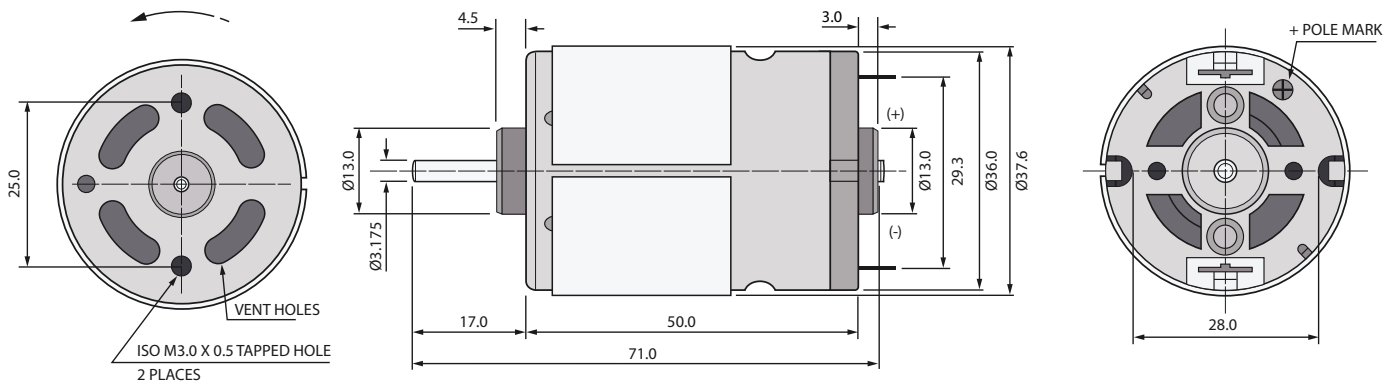

UNIT: mm

