

PTRS-545SA

CARBON BRUSHED DC MICRO MOTOR

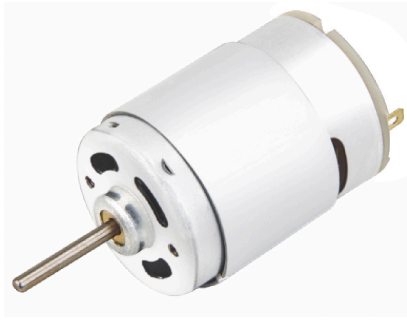

38D x 50mmL (1.50D x 1.97inL)

VOLTAGE	8.0~16.0V
HOUSING LENGTH	50.0mm (1.97in)
DIAMETER	37.6mm (1.48in)
SHAFT LENGTH	71.0mm (2.80in)
SPEED (NO LOAD)	4244 RPM
POWER (AT MAX EFF)	5.2W
TORQUE (AT MAX EFF)	134.1 g·cm (13.1 mN·m)
OPERATING TEMPERATURE	-30°C ~+80°C
WEIGHT	165g (5.82oz)

MODEL NUMBER	VOLTAGE (V)		NO LOAD		AT MAXIMUM EFFICIENCY				STARTING			
	OPERATING RANGE	NOMINAL	SPEED RPM	CURRENT A	SPEED RPM	CURRENT A	TORQUE g·cm	TORQUE mN·m	OUTPUT W	TORQUE g·cm	TORQUE mN·m	CURRENT A
PTRS-545SA-2396	8.0~16.0	12.0	4244	0.10	3624	0.59	134.1	13.1	5.2	918.6	90	3.44

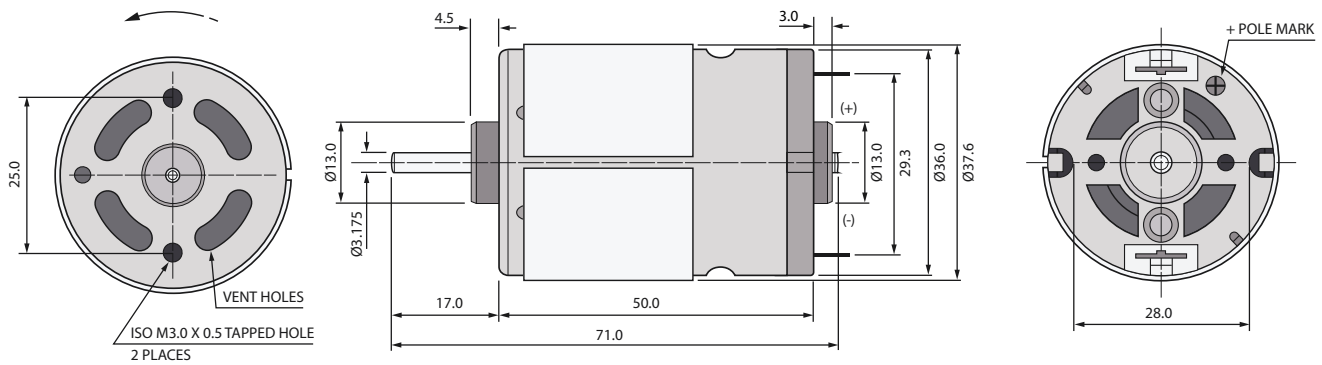

UNIT: mm

