

JD100A Inline Box Fan

100mm (3.9in)



GENERAL SPECIFICATIONS

- Impeller:** SGCC
- Housing:** SGCC
- Life:** 30,000 hours
- IP Rating:** IP44
- Operating Temp:** -40°C~+80°C
- Wire:** 20 AWG

FEATURES

- High efficiency inlet design
- Whisper-quiet performance
- Lubricated sealed ball bearings
- External rotor motor w/backward-curved centrifugal fan
- Includes housing, impeller, motor, base, and ABS connection box

MODEL	VOLTAGE (V)	FREQ (Hz)	CURRENT (A)	POWER (W)	SPEED (RPM)	AIR FLOW (m ³ /h)	AIR FLOW (CFM)	PRESSURE (Pa)	NOISE (dBA)	INSULATION CLASS
JD100A-H	230	50	0.31	73	2400	325	191	328	64	F
JD100A-M	230	50	0.28	65	2140	210	124	218	61	F
JD100A-L	230	50	0.26	61	1870	187	110	328	58	F

Performance Curves

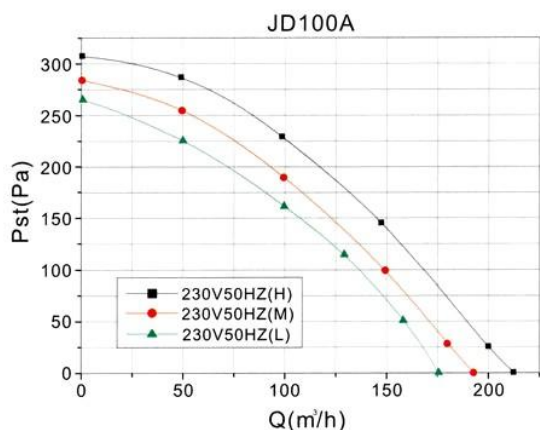

Dimensions

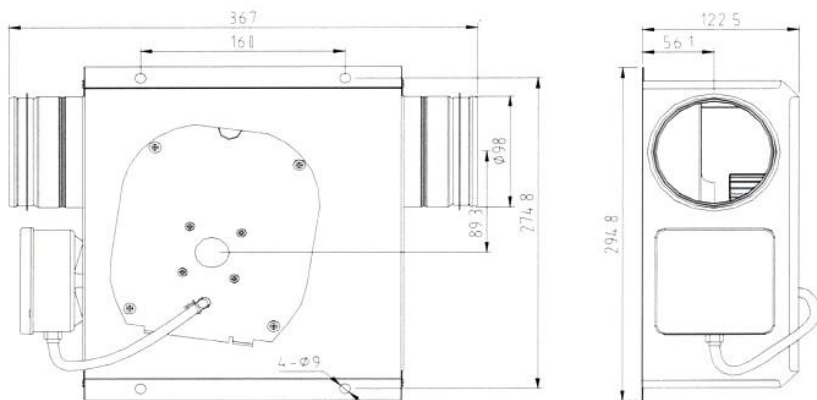

Note: All dimensions in mm

Applications

Commercial and industrial applications, condominiums, apartments, hospitals, hotels, and other areas with limited space.



T 1.888.546.0524 • F 1.610.647.0319
 email: sales@pelonistech.com • www.pelonistechnologies.com

